

## ASSESSMENT OF MIKE21 MODEL IN DAM AND DIKE-BREAK SIMULATION\*

M. ZOLGHADR, M. R. HASHEMI\*\* AND S. M. A. ZOMORODIAN

Dept. of Water Engineering, Shiraz University, Shiraz, I. R. of Iran  
Email: hashemi@shirazu.ac.ir

**Abstract**– A numerical model called MIKE21 was evaluated for simulation of dam and dike breaks. In recent years in Iran and other parts of the world some dike-breaches have been reported. Application of two-dimensional models in simulation of dike-breaches is inevitable, because of the nature of the flood propagation after the break. However, in Iran, there are very few two-dimensional models used in river and floodplain issues. Hence, the performance of MIKE21 as a numerical model for simulation of dike break was investigated in this research. MIKE21 was originally developed for flow simulation in coastal areas, estuaries and seas. MIKE21's performance in simulation of dam and dike-break was studied via comparison with analytical solutions, other numerical approaches and available experimental data. Fair agreement has been observed, but care should be taken when modeling shock waves with MIKE21. The study was finally extended to a real case study. Some dike-break scenarios were considered in the Helleh River, in Iran and the results are discussed and presented.

**Keywords**– MIKE21, dam-break, dike-break, shock wave

### 1. INTRODUCTION

Dam and dike-breaks resemble each other in many aspects, but there are two main differences; firstly when a dam breaks, the outflow runs in the downstream river with defined banks in almost one dimension. However, when a dike-breaks, there is no specified channel after the breach and the flow runs on a flat plain in different directions. Hence, most of the dam-break analysis models are one-dimensional, like DAMBREK, MIKE11 and Hec-Ras (dam-break module) etc. The two-dimensional shallow water equations are widely accepted for dike-break simulations, even if the governing equations assumptions are not completely satisfied, especially near the breach point and in the first stages of breaking, where strong streamline curvatures occur [1]. The second difference between dam and dike-breaks is that, the shock wave produced by the dam-break is much stronger than that produced by a dike-break, because of the larger height of the dam compared to the dike.

The history of dam-break studies began more than a hundred years ago. The first studies were conducted in one dimension and various analytical solutions were developed with different assumptions. In 1892, Ritter suggested a solution for total and instantaneous collapse of a dam on a dry bed by the Method of Characteristics [2]. Sixty years later, Dressler studied the effect of hydraulic resistance on dam-breaks [3]. In 1954, Whiteham divided the water surface profile into 2 zones and took the resistance effect into account on the downstream part. An analytical solution for total and instantaneous collapse of a dam on a wet bed by Method of Characteristics was proposed by Stoker in 1957 [4]. Subsequently in 1983, Hunt studied the effect of bed slope on total and instantaneous collapse of a dam on a wet bed by kinematic wave approximation [5]. Stoker's method was simplified by Wu et al. [6]. Some numerical approaches also have been developed in this regard [7, 8].

---

\*Received by the editors March 15, 2010; Accepted August 9, 2010.

\*\*Corresponding author

With the aid of numerical methods, two-dimensional modeling of dam and dike-breaks which are not possible by analytical methods, is possible. In 1996, Zhao et al. proposed a finite volume method for modeling shock waves. Three approximate Riemann solvers, F.V.S, F.D.S and Osher were prepared and the ability of the 3 methods was shown. One and two-dimensional dam-breaks on wet bed and oblique hydraulic jump were modeled successfully [9]. In 2000, Zoppou et al. presented a numerical approach and modeled one and two-dimensional dam breaks on wet and dry beds and also circular dam-breaks. They observed a good agreement of one-dimensional results with analytical solutions, and also two-dimensional results with other numerical methods [10]. In 2001, Aureli and Mignisa proposed a finite difference shock capturing method for simulation of dike-breaks. Experimental data from a laboratory flume were used to verify the model [11]. Subsequently in 2004, Gottardi and Venutelli presented a finite volume method with a second order central scheme. An analytical solution, results of other numerical methods and experimental data were used to verify the model [12].

As the knowledge of the authors show, there have been very few studies on the modeling of dam and dike-breaks by MIKE21. As an example, McCown et al. in 2001 considered the capabilities of the recent version of Mike21 in comparison with older versions. These capabilities included modeling of high Froude number flows and wetting and drying. These improvements were illustrated by some examples like flow over a dike and an instantaneous dam-break on a dry bed. The results of sudden dam-breaks were compared qualitatively with similar studies [13].

It should be mentioned that DHI (Danish Hydraulic Institute) software such as MIKE11 and MIKE21 are widely used in Iranian academic and consultant organizations [e.g., 14 and 15]. MIKE21 is a software for two-dimensional simulation of unsteady free surface flows, originally developed for simulation of flow in seas, estuaries and coastal areas [16]. This model is developed by DHI. As floodplain applications and shock waves are inevitable portions of hydraulic engineering, in this research, MIKE21's performance in simulation of dam and dike-breaks was studied. The model results were compared with analytical solution, other numerical schemes and experimental data. As a real case study, Helleh River, which is located in the south of Iran, is considered. The dike-break and flow propagation on an initially dry topography is presented and discussed in some detail.

## 2. GOVERNING EQUATIONS

Around the failure point of a dike, the flow can be approximated by two-dimensional depth averaged Navier Stokes equations (Shallow Water Equations). Neglecting Coriolis and wind force, the equations can be expressed as continuity and momentum in  $x$  and  $y$  directions [16, 17]:

Continuity equation:

$$\frac{\partial \eta}{\partial t} + \frac{\partial q_x}{\partial x} + \frac{\partial q_y}{\partial y} = 0 \quad (1)$$

Momentum equation in  $x$  direction

$$\frac{\partial q_x}{\partial t} + \frac{\partial(q_x^2/H)}{\partial x} + \frac{\partial(q_x q_y/H)}{\partial y} = -gH \frac{\partial \eta}{\partial x} - \frac{g q_x \sqrt{q_x^2 + q_y^2}}{H^2 C^2} + \nu \left[ 2 \frac{\partial^2 q_x}{\partial x^2} + \frac{\partial^2 q_x}{\partial y^2} + \frac{\partial^2 q_y}{\partial x \partial y} \right] \quad (2)$$

Momentum equation in  $y$  direction

$$\frac{\partial q_y}{\partial t} + \frac{\partial(q_y^2/H)}{\partial y} + \frac{\partial(q_x q_y/H)}{\partial x} = -gH \frac{\partial \eta}{\partial y} - \frac{g q_y \sqrt{q_x^2 + q_y^2}}{H^2 C^2} + \nu \left[ 2 \frac{\partial^2 q_y}{\partial y^2} + \frac{\partial^2 q_y}{\partial x^2} + \frac{\partial^2 q_x}{\partial x \partial y} \right] \quad (3)$$

where  $\eta$  is water surface elevation,  $q_x$  and  $q_y$  are the flux per unit length in  $x$  and  $y$  directions respectively,  $H = \eta + h$  is the total water depth and  $h$  is water depth below Still Water Level (SWL; Fig. 1),  $g$  is acceleration due to gravity,  $C$  is Chezy friction coefficient and  $\nu$  is eddy viscosity.

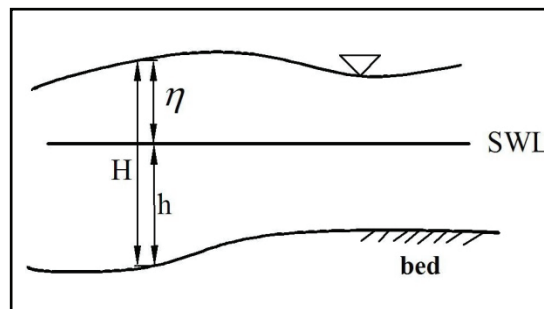

Fig. 1. Illustration of stage parameters in the governing equations

MIKE21 uses implicit finite difference method to solve the governing equations on a staggered grid. The numerical scheme is called ADI (Alternating Direction Implicit). ADI has been widely used because of its wide range of stability and ability to form a balance between computational cost and precision [18].

### 3. MODEL EVALUATION

Different numerical scenarios were considered to evaluate MIKE21 in simulation of a dam and dike-break. At first, Stoker's analytical solution is considered for the one-dimensional case. In the next stage, Gabutti and MacCormack numerical schemes are used as numerical bench marks for the evaluation of MIKE21 in a two-dimensional case. Finally, experimental data were considered.

#### a) One-dimensional dam-break

In 1957, Stoker presented an analytical solution for the sudden collapse of a dam in an infinite, frictionless and flat rectangular channel with finite tail water depth [4]. The initial conditions are shown in Fig. 2. The same conditions were applied to MIKE21. However, it was not possible to set the Manning roughness coefficient equal to zero, therefore a very small magnitude was introduced to the model to ignore the bed friction. It should be mentioned that, in fully dynamic equations (MIKE21) where all of the forces (i.e., inertia, pressure, friction, gravity, turbulent shear stress) appear in the momentum equation, the friction can be ignored. However, in the uniform flow equation where just friction and gravity forces appear the friction force cannot be set to zero.

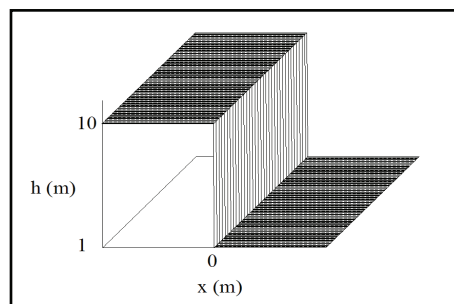

Fig. 2. Schematic of initial condition of one-dimensional dam-break test case

Figures 3a and 3b show the comparison between the analytical solution and the MIKE21 results in the prediction of water surface and velocity profile 3.2 seconds after the break, respectively. Although an overall agreement is observed, some discrepancies between the analytical solution and the MIKE21 results can be observed. Apart from MIKE21, numerical scheme draw backs- sensitivity to eddy viscosity which

will be discussed- the disagreements may be due in part to numerical errors in one-dimensional flow condition.

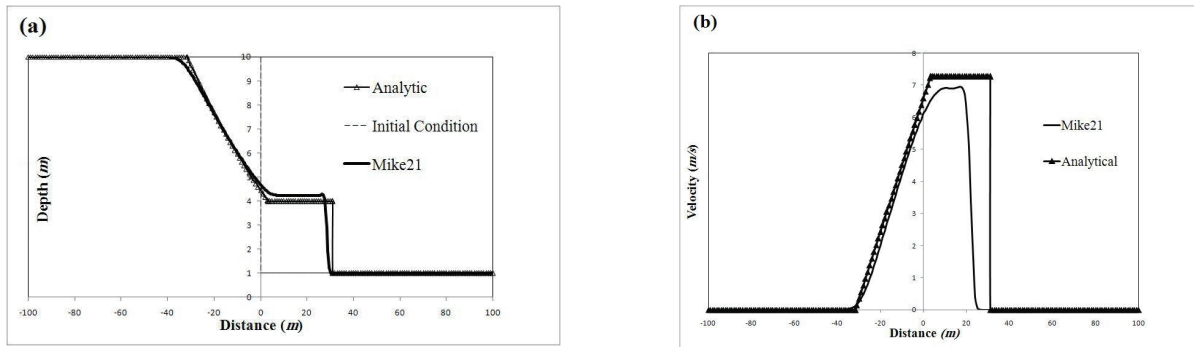

Fig. 3. a) Comparison of water surface profiles b) Comparison of velocity profiles

**b) Two-dimensional dam-break (Partial dam-break)**

There is no analytical solution for two-dimensional dam or dike-break problems. Hence, only comparisons with other numerical models and/or experimental data can be used. Such comparisons are discussed in the next section.

**1. Comparison with MacCormack and Gubutti numerical schemes (Classical dam-break):**

MacCormack and Gubutti numerical schemes [17] were considered as bench marks for simulation of partial dam-break. Some other researchers have considered them as criterion to validate their numerical methods [19-21]. MacCormack and Gubutti numerical schemes have been developed on the basis of finite difference methods. In order to verify MIKE21, the results of a test case [17] generated by MacCormack and Gubutti numerical schemes are used.

As Fig. 4 shows, the test case was a 200m\*200m square domain with an asymmetric opening in the middle, 75m long and 10m wide. The reservoir and tail water depths were 10m and 5m respectively. Figure 4a shows the computational domain. Initial conditions are illustrated in Fig. 4b. Water depth contours 7.1 seconds after the instantaneous break are shown in Fig. 5. In order to assess the performance of MIKE21, transverse water surface profiles were compared with the benchmarks at three stations, namely the upstream of the breach ( $i=16$ ), the middle of the breach ( $i=20$ ) and the downstream of the breach ( $i=24$ ). The results from this comparison are shown in Fig. 6.

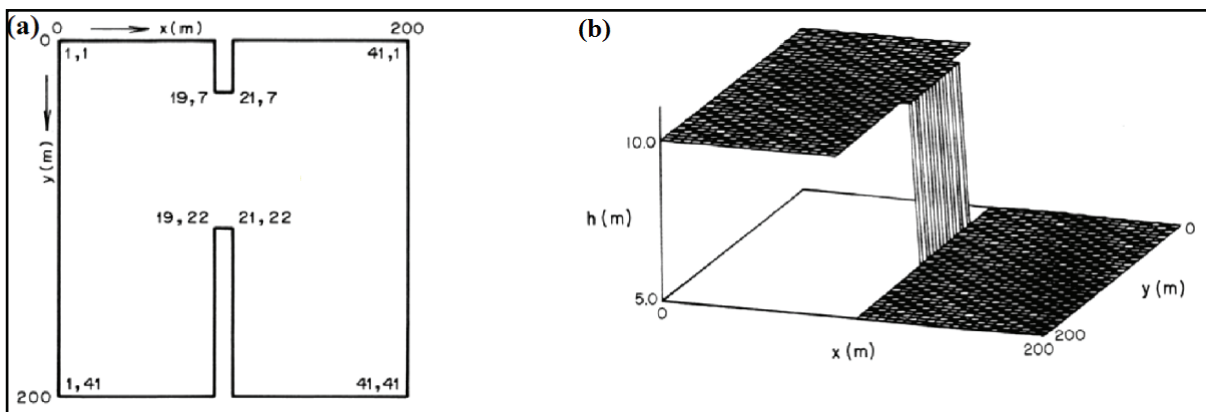

Fig. 4. a) Computational domain b) Initial conditions [15]

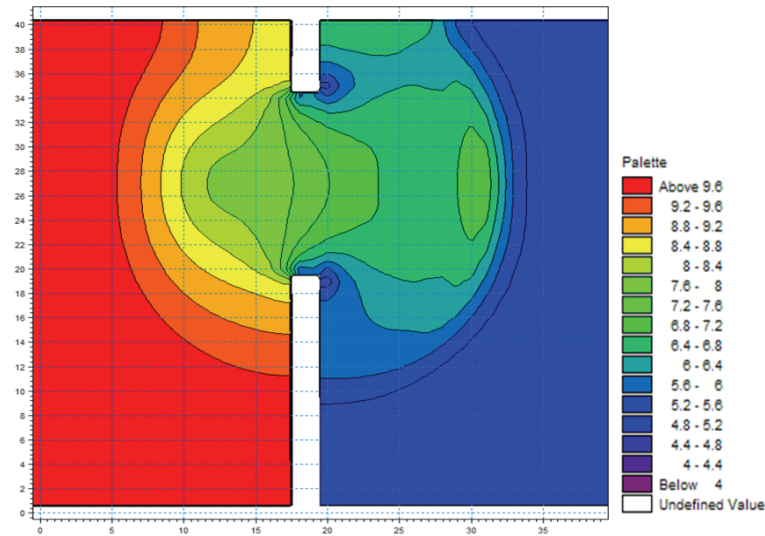

Fig. 5. water depth contours 7.1s after the break

Figure 6 shows that MIKE21 does simulate transverse water surface profiles in these three locations reasonably well. This demonstrates the ability of MIKE21 in the simulation of two-dimensional dam-break problems.

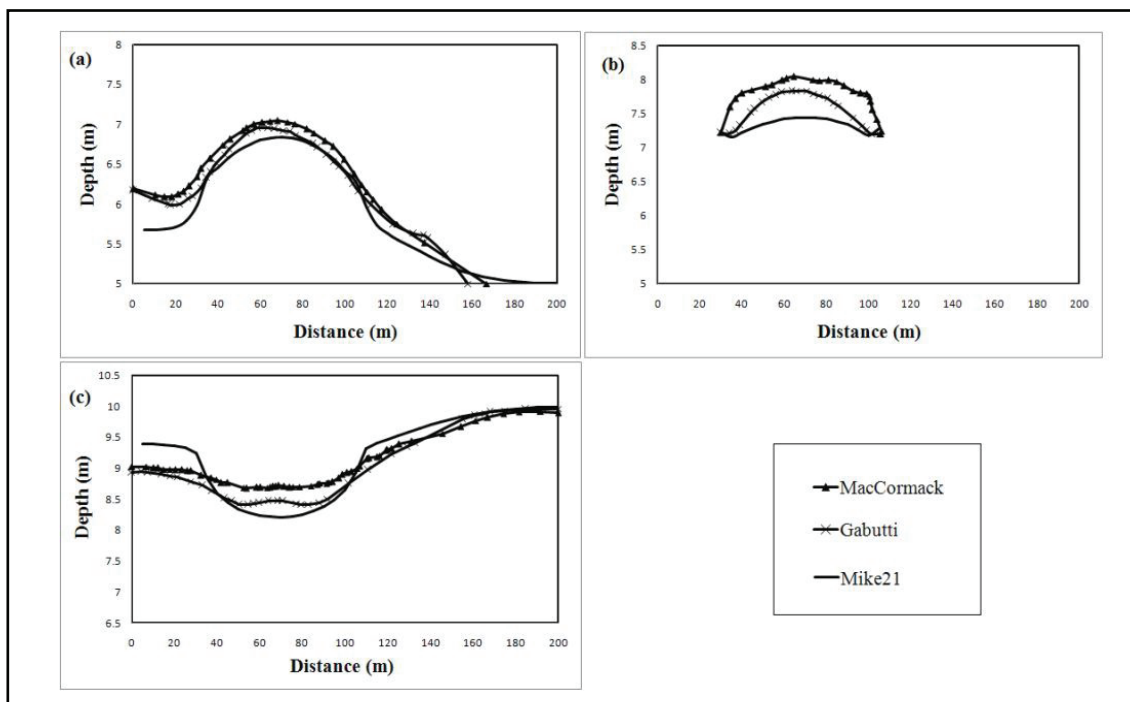

Fig. 6. Comparison of transverse water surface profiles; a) Up stream of the break (i=16), b) Middle of the break (i=20), c) Downstream of the break (i=24)

**Effect of eddy viscosity:**The results of this study showed that MIKE21 results were highly sensitive to the eddy viscosity magnitudes specified.

Figure 7 shows the water surface profile for a two-dimensional dam-break problem with different eddy viscosity coefficients. The sensitivity of the numerical results to eddy viscosity has been observed in other studies of dam-break problems. Liang et al. (2006) investigated the eddy viscosity effect on ADI

(Alternating Direction Implicit) method. Figure 8 shows the results of their study. According to Fig. 7 and 8, eddy viscosity coefficient has an important effect on ADI schemes, especially on the frontal of the shock wave. It is possible to simulate shock waves with ADI schemes, but care should be taken in the definition of an appropriate eddy viscosity coefficient, whereas shock capturing schemes do not require any special treatment when a shock occurs [17]. Appropriate selection of eddy viscosity coefficient is hard in practice and requires trial and error, and comparisons with available benchmarks and numerical experiences. An upper limit for eddy viscosity is introduced in MIKE21 scientific manual for eddy viscosity:

$$\frac{\nu \Delta t}{\Delta x^2} \leq \frac{1}{2} \quad (4)$$

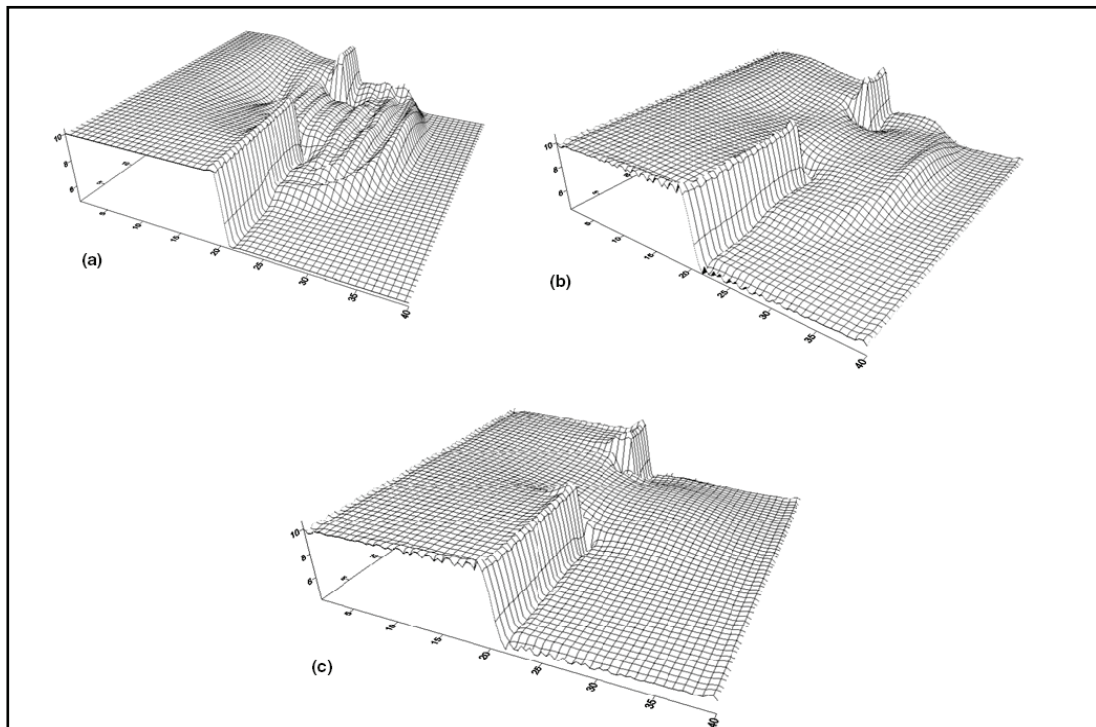

Fig. 7. The effect of eddy viscosity coefficient on water surface profile produced by MIKE21, a)  $\nu = 0 \text{ m}^2/\text{s}$  b)  $\nu = 5 \text{ m}^2/\text{s}$  c)  $\nu = 40 \text{ m}^2/\text{s}$

According to this formula, eddy viscosity coefficient depends on time step ( $\Delta t$ ) and grid size ( $\Delta x$ ). This relation is developed on the basis of stability considerations of MIKE21. The user's manual provides guidance about this formula and the model setup parameters which result in  $\nu < 125$ , whereas Fig. 6 was developed by consideration of a  $40 \text{ m}^2/\text{s}$  eddy viscosity coefficient. Hence, the problem in determination of eddy viscosity coefficient still remains and this relation just gives a rough estimation for the upper bound of the eddy viscosity coefficient to satisfy the stable requirements. Experiences in numerical modeling in similar cases and comparison with experimental data provide guidance in coping with this problem.

**2. Two-dimensional dam-break; Experimental data:** In another case, MIKE21 results were compared with experimental data too. The results of a study published by Aureli et al. (2008) were used for this purpose. Aureli et al. (2008) modeled rapidly varying flows caused by sudden dam-break by a two-dimensional finite volume numerical method. They used experimental data to verify the numerical model. Imaging technique for acquisition of experimental data was utilized. Figure 9 shows the experimental setup. The reservoir and tail water depths were  $0.5$  and  $0.01 \text{ m}$  respectively and Manning roughness



coefficient was 0.007. Figure 10 shows the comparison between the experimental data, finite volume results [1] and MIKE21 results in simulation dam-break flow in different time steps ( $t$  is time after dam-break). A fair agreement is seen, especially during the initial stages of the break, but considerable discrepancies appear as time proceeds. However, the finite volume results [1] remain reasonable through longer times. This can be related to the numerical scheme of the finite volume [1] which is shock capturing.

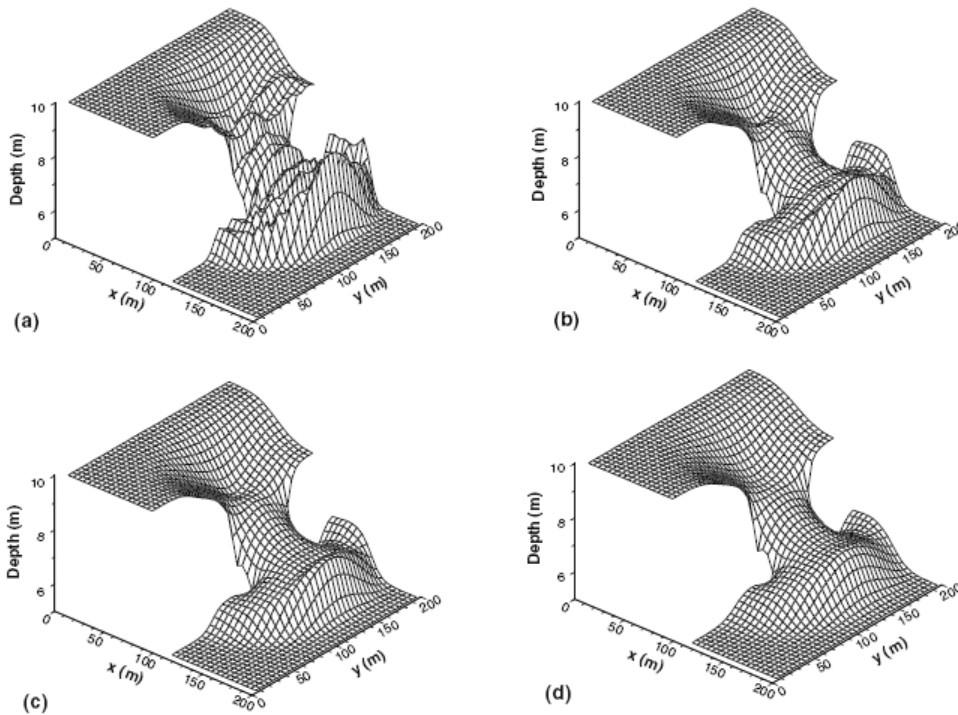

Fig. 8. The effect of eddy viscosity coefficient on water surface profile produced by an ADI model, a)  $\nu=10^{-6} \text{ m}^2/\text{s}$  b)  $\nu=3 \text{ m}^2/\text{s}$  c)  $\nu=5 \text{ m}^2/\text{s}$  d)  $\nu=10 \text{ m}^2/\text{s}$  [18]

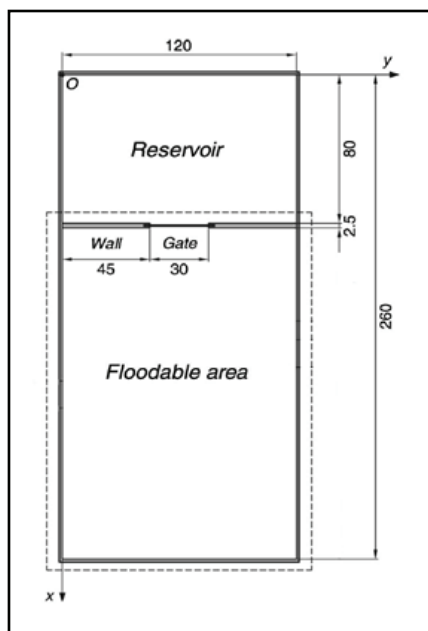

Fig. 9. Main dimensions of the experimental facility in centimeters [1]

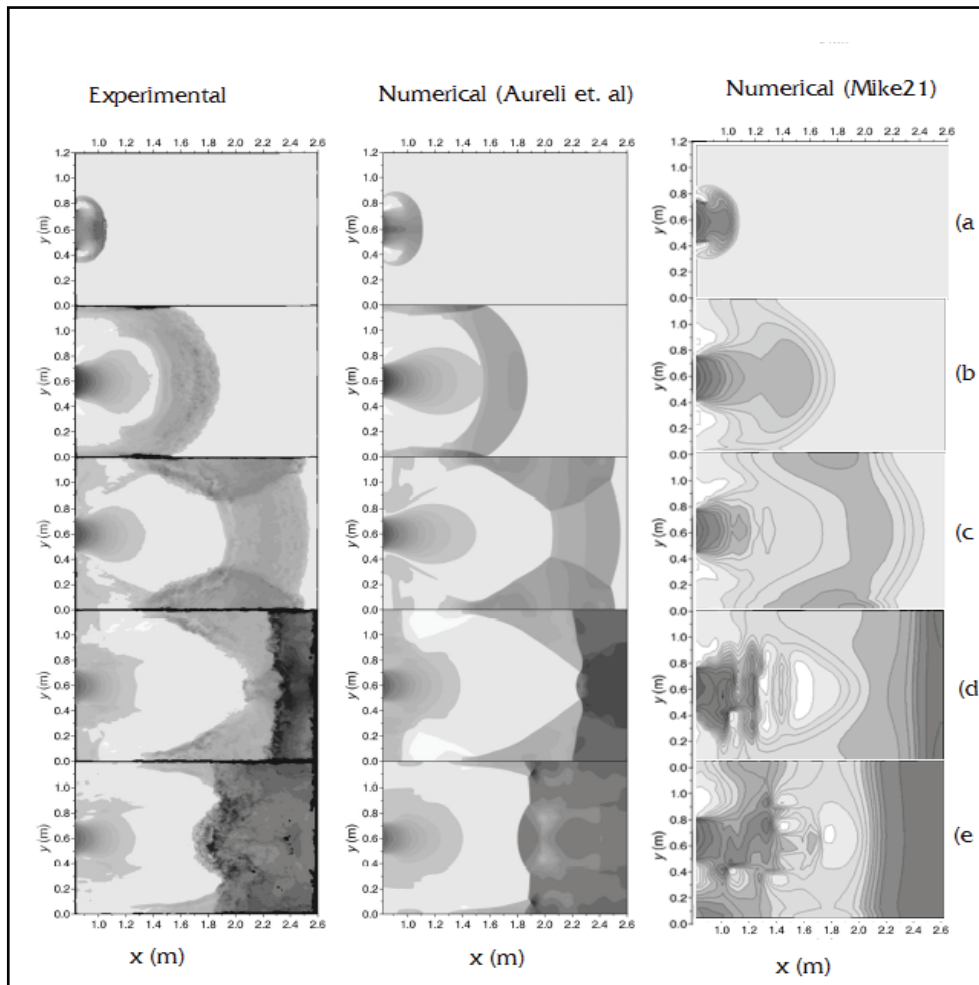

Fig. 10. Comparison of experimental data, a finite volume scheme [1] and ADI scheme (MIKE21) results in simulation of dam breach; a)  $t=0.24$  s b)  $t=0.94$  s c)  $t=1.64$  s d)  $t=2.35$  s e)  $t=3.05$  s

### c) Two-dimensional dike-break; Experimental data

In the previous example, experimental dam-break was studied. In another case, the experimental dike-break is considered in this section. A major difference between dam and dike breaks experimental cases is that, in the dike break there is a flow in the main flume and flow (due to the break), leaving this flume perpendicular to the main flow direction. In the dam break case there is no main flume and flow starts from rest in the downstream area.

Results of an experiment designed for dike-break, published by Aureli and Mignosa (2001), were considered to evaluate the MIKE21 results [11]. Referring to Fig. 11, the experimental setup was composed of a tilting laboratory flume, 10 m long and 0.3 m wide. One of the side walls was replaced by two plates in order to create a lateral opening which reproduces the breach. A lateral plane was added to the flume, in addition to the opening, in order to let the outflow propagate laterally outside the breach. The breach width was 0.28 m. Inflow discharge and slope were 0.035 cms and  $S=0.1\%$  respectively. The Manning roughness coefficient for the bed and sidewalls of the flume is 0.009. Water depths and velocity profiles inside the flume just upstream of the breach section were measured by means of a point gauge and an acoustic Doppler velocimeter, respectively. The profiles were time-averaged to remove fluctuations caused by turbulence or by the inflow discharge from the pump. The total outflow discharge from the



breach has been measured by means of a weir located at the end of the gutter which surrounds the plane [11].

The experimental tests were simulated by MIKE21. It is generally necessary to specify water surface elevation or flux or a predefined relationship between flux and water elevation as boundary conditions for two-dimensional flow models. For dike-break flow simulation, three open boundaries (inflow, breach and outflow) should be specified (Fig. 11). The inflow and outflow discharges were applied as upstream and downstream boundary conditions, respectively. The closed boundaries (channel banks) were set as no-slip boundary condition.

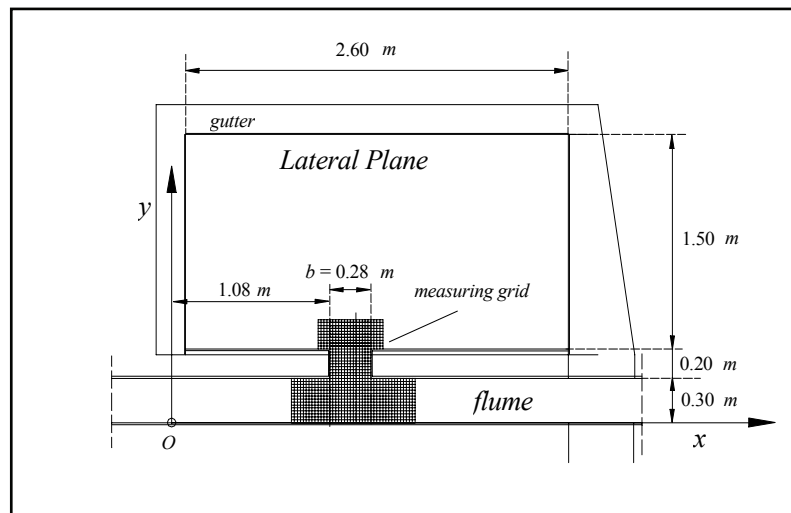

Fig. 11. Plan view of the breach zone in the experimental setup [11]

Generally, depending on the purpose of the modeling, different kinds of boundary conditions should be applied to the breach point. If the flow simulation after the breach is required, the breach is actually a part of the computational domain and the boundary condition should be specified beyond the breach point in the flood plain. In this case the breach point is regarded as an internal boundary. It should be mentioned that if the backwater flow effect from the floodplain on the breach is significant, it is not physically possible to define a proper boundary condition at the breach or limit the flow simulation to the breach point. In other words, the information downstream of the breach should be included in the breach boundary condition, which is not possible without modeling flow after the breach.

If the computational domain is limited to the breach point, the boundary condition should be specified along the breach. Free overfall or weir formulae (submerged or unsubmerged) are common types of breach boundary conditions [22]. Therefore, discharge magnitude should be known in the breach point. In the current experiment the dike breach flow was measured. But, as an alternative, the flux through the breached dike was estimated and used as the boundary condition on the breach. The discharge through the dike-break was estimated using an empirical formula developed by Kamrath et al. [23]. In this formula, the discharge through the breached dike depends on flow depth, flow main velocity, width of the breach and influencing channel width. Accordingly, the dike-breach discharge is given by,

$$Q_{br} = 0.385\mu^* \sqrt{2gb_{br}} h_{fp}^{2/3} \quad (5)$$

in which  $Q_{br}$  is the discharge through the breached dike,  $\mu^*$  is the normalized dike-breakage parameter,  $g$  is the gravity acceleration,  $b_{br}$  is the breach width and  $h_{fp}$  is the depth of water in the flood plain beside the dike. The breakage parameter is computed using the following relations:

$$\mu^* = 0.1146 \ln(\xi) + 0.6895 \tag{6}$$

where

$$\xi = 0.4\sqrt{Fr} \left(\frac{b_i}{b_{br}}\right)^2 \tag{7}$$

$Fr$  is computed for the incoming flow upstream of the breach,  $b_i$  is the influencing channel width. As mentioned before, the discharge was measured for the experimental data used in this study. Accordingly, Eq. (5) was validated using these data. A 5.6% difference was observed between the experimental data and the formulae result. This suggests that this formulae can be applied where the external boundary condition for the dike-break should be determined

After setting up the model, the velocity field was computed and compared with the experimental data. Fig. 12 shows the comparison between numerical and experimental velocity profiles toward the breach ( $y$  direction) in a region inside the flume in front of the breach. Figure 13 shows the general pattern of computed flow near the breach.

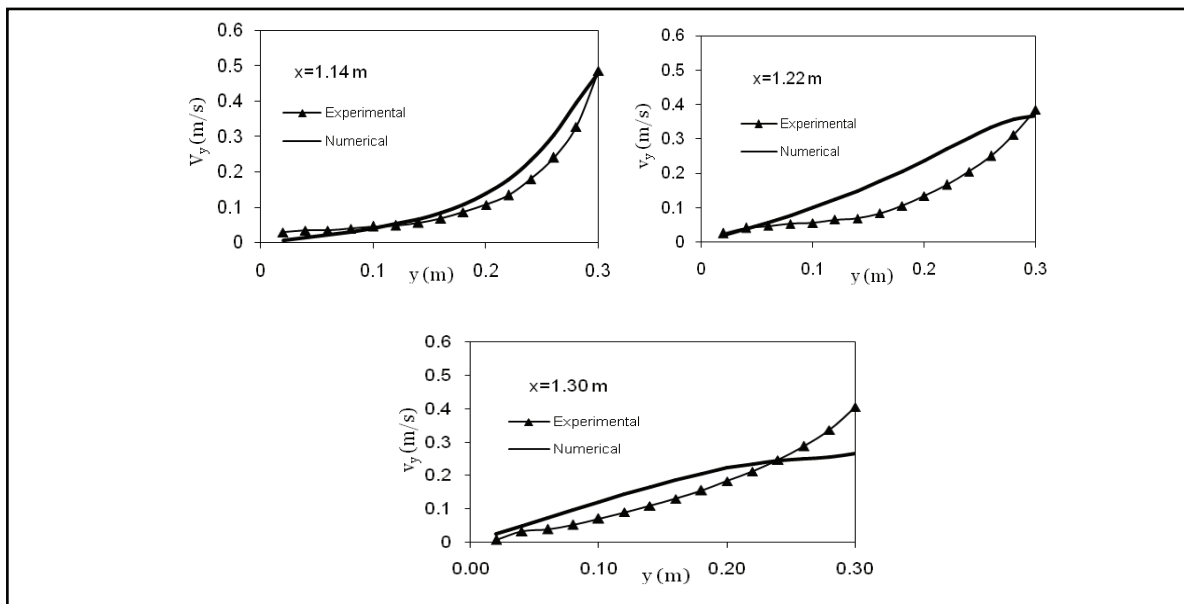

Fig. 12. Comparison between experimental data and MIKE21 results at different stations (see Fig. 12 and 14)

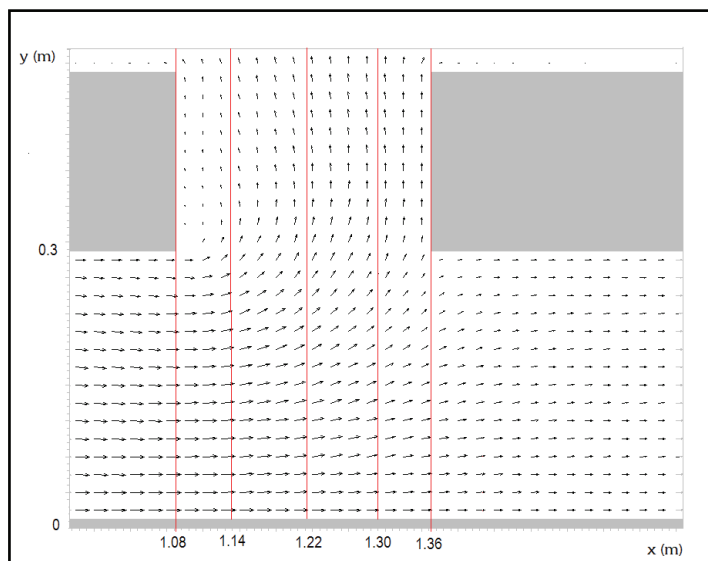

Fig. 13. Computed velocity field near the breach using MIKE21

As can be seen in Fig. 12, the overall agreement is good. The measured velocity profiles were collected by locating the transducers 0.02 m above the bed, while the numerical results are depth-averaged values. Existence of the solid wall perpendicular to the breach imposes sharp curvatures in the water surface profile. This leads to a non-hydrostatic pressure distribution which is a source of discrepancy when shallow water equations are used [11]. Three-dimensional models may end in better results in such cases. Furthermore, discharge through the breach is estimated according to “dike breach formula”. This method overestimates the measurements about 5.6%. This is also another source of error. The MIKE21(2000) model does not contain a shock capturing scheme. The shock waves usually occur near rapid change of flow state like dam or dike-breaches. According to Toro [24], “Shock waves are discontinuous solutions of hyperbolic conservation laws obeying some precise mathematical conditions”. Shock waves are generated where a sudden transformation of a subcritical flow to a supercritical flow or vice versa takes place. Shock capturing numerical methods avoid discontinuities when this situation occurs. Opening in the side wall of the flume, which represents the dike-break, was instantaneous. This led to a shock wave. There have been some attempts to overcome this problem of MIKE21. As mentioned, McCowan et al. in 2001 illustrated the enhancements of the numerical scheme of MIKE21 and simulated some rapidly varied flow such as hydraulic jump and dam-break using this software [13].

#### 4. CASE STUDY

##### a) Helleh River

As a case study, the Helleh River in the southwest of Iran is considered. The Helleh River is located in a flat region near Persian Gulf. The river is 95 km long with an average slope of 0.0003. It has a main channel which can convey up to a 2-year flood ( $1100 \text{ m}^3/\text{s}$ ). Larger floods often lead to inundation of very large areas around the river and cause significant damage to civil structures, farms and sometimes human loss. In 1966, a severe flood opened a new branch in the river which has caused several issues in the region. For protection against floods, people and local authorities have started to construct ring dikes around villages, and are planning to add a mainline dike parallel to the river channel. Using MIKE21, the proper locations for emergency breaching (i.e., fuse plug spillways) in the dike system was studied and presented in some detail. Apart from MIKE 21, a one-dimensional model of the river was developed using HEC-RAS (Version 3.1.3). Two hundred twenty two cross sections, more than 41000 topographical points and measured tide levels at the end of the river were used as the data for development of the two models. The selected region for dike-break simulation is shown in Fig. 14. Four residential districts are located in this zone, and there are also plenty of agricultural lands. The ring dikes are also visible in this figure. A mainline dike is developed by use of HEC-RAS and is considered in the MIKE21 model for simulation of dike-break scenarios.



Fig. 14. Selected region for dike-break simulation (residential regions are named, upstream is located in the right side)

**b) Comparison of HEC-RAS 1-D and MIKE21 2-D model before the breach**

The Helleh River was initially modeled by use of HEC-RAS. A sub-reach was selected for two-dimensional simulation including dike breach scenarios. Figure 15 shows the reaches of the Helleh River simulated by HEC-RAS and the sub-reach modeled by MIKE21. Boundary and initial conditions of the MIKE21 model were extracted from HEC-RAS outputs. A comparison between HEC-RAS and MIKE21 results in the prediction of stage hydrograph with a 25-year return period. The location of the comparison is shown on Fig. 16a. In this comparison the flow was restricted between the dikes. Figure 16b shows the comparison between the two model outputs. This figure considers a 33 hour time period in the vicinity of the peak point. The results of both models for prediction of water surface elevation are very close. However, there is about a 1 hour difference in the predicted time to peak. Overall, it can be concluded that wherever the flow generally runs in a single dimension, one-dimensional models are suitable choices for prediction of maximum water surface elevation. This is a vital factor in the design of dikes and floodwalls. However, prediction of flood wave travel time in one-dimensional models is accompanied by some errors. These errors can be related to the governing equations of the one-dimensional flow compared with two-dimensional flows which represent a more realistic condition of the flow. The distance between cross sections of one-dimensional model can be another source of error, compared to the two-dimensional model which uses closer points (fine grids) to reproduce the bathymetry and topography.

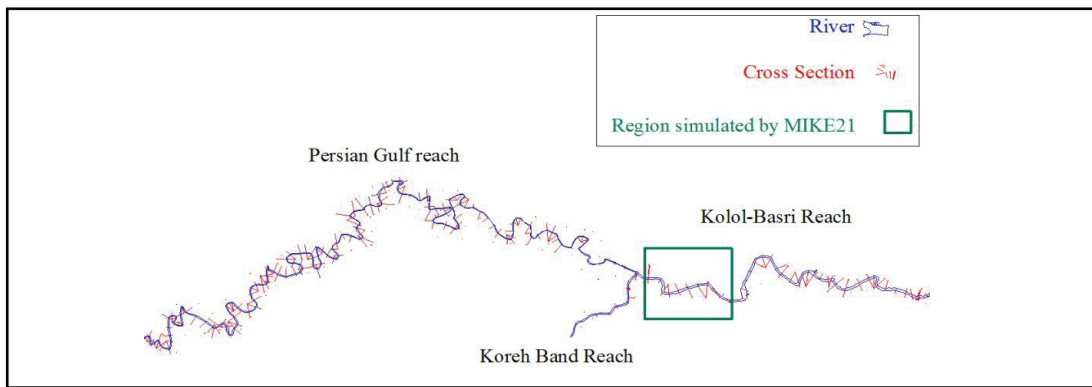

Fig. 15. Helleh River and its main reaches with the region simulated by Mike21

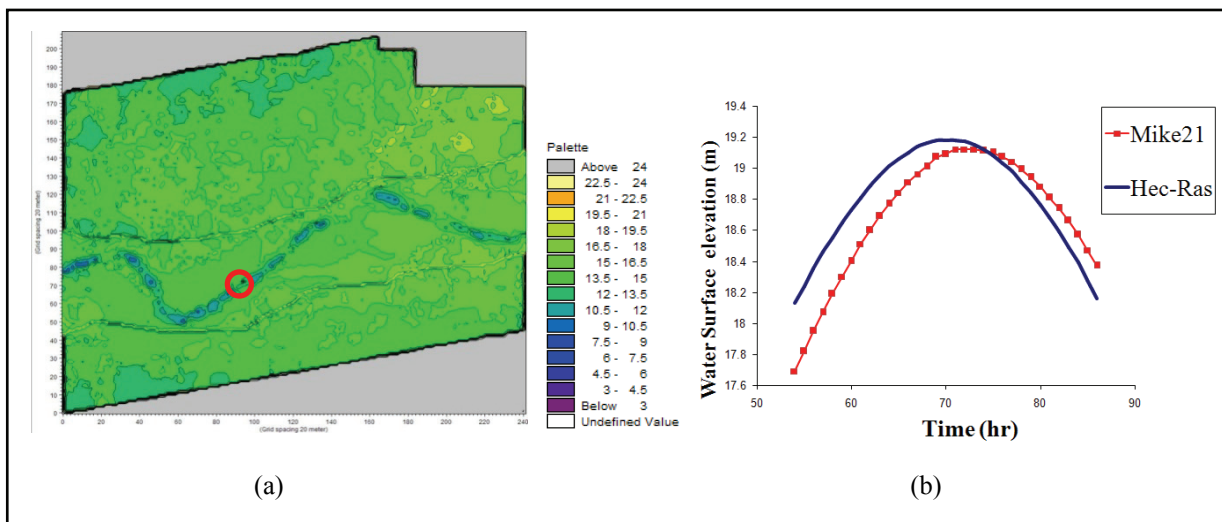

Fig. 16. (a) Location of comparison (b) Comparison of stage hydrograph simulated by HEC-RAS and MIKE21 models

### c) Dike break scenarios

As a dike-break scenario, a 60 m opening was considered between Heidary and Engali to observe the fuse plug location effect on neighbor villages. A  $10 \text{ m}^2/\text{s}$  is considered for eddy viscosity coefficient. The flood wave travel time was 14.2 and 14.25 min to Heidary and Engali respectively, and approximately reached the closed boundary at the same time. The closed boundaries were extended as far as topographical data were available. Figure 17 illustrates this scenario. Water depth contours 14.2 min after the break is shown in Fig. 18. Because of the flatness of the floodplain, the flood runs in every direction, even opposite the main flow direction in the river. This emphasizes that utilization of two-dimensional models in similar cases is inevitable. Hence, one-dimensional models- which form the majority of river engineering models- such as HEC-RAS and MIKE11 are inefficient in this regard.

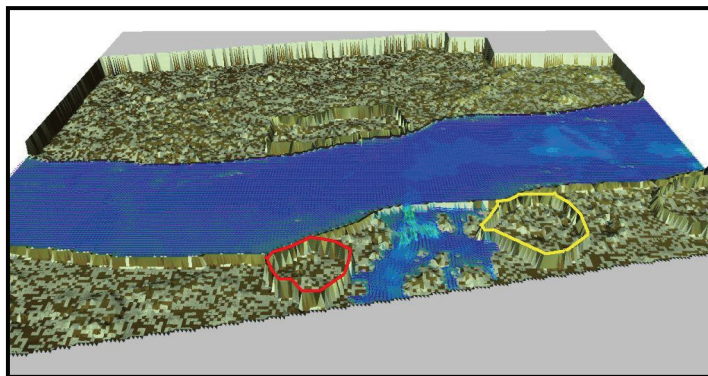

Fig. 17. First dike-break scenario, 14.2 min after the break (Engali ring dike in red and Heidary ring dike in yellow, upstream is located on the right side)

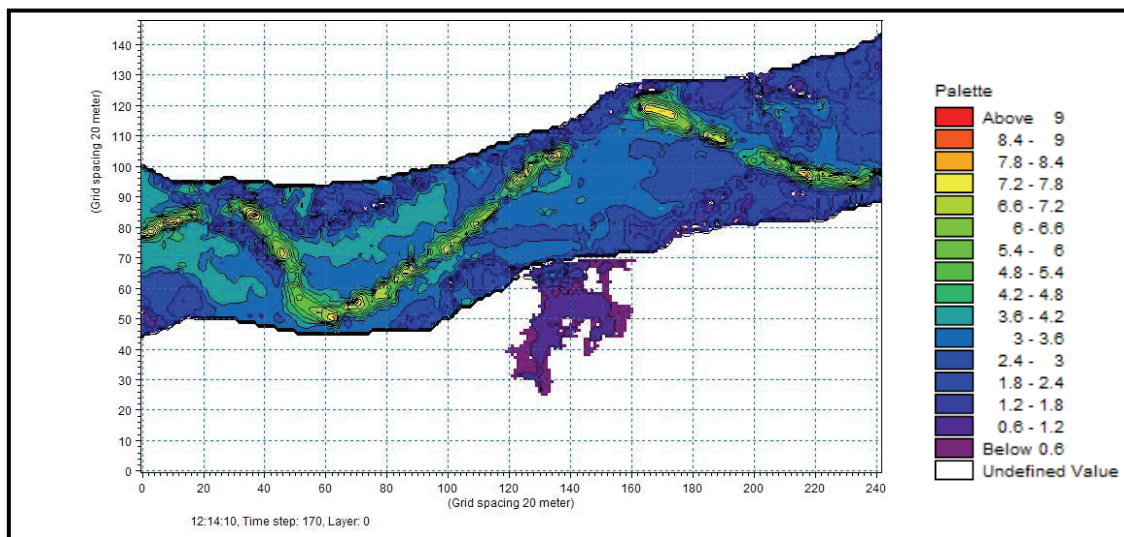

Fig. 18. Water depth contours, 14.2 min after the break in the first scenario (Engali ring dike in red and Heidary ring dike in yellow, upstream is located on the right side)

As another scenario, two different breach widths, 63.2 m and 82.5 m, were considered near Dashti shabankare. This village is the most populated region located at the right side of the river. The flood wave travel time was considerably different for the two widths. Table 1 shows the results of this scenario and the effect of breach width on flood wave travel time. The average velocities are in the same order with the computed velocity based on Manning formula (very rough estimate). The flood reaches the closed boundaries after 63.75 min for the 63.2 m breach width. Figure 19 shows this scenario. Water depth



contours, 30 min after the break are plotted in Fig. 20. The propagation of flood in different directions can be observed in this figure.

Table 1. Results of the second scenario

Breach width (m)	Distance between breach and the village (m)	Flood wave travel time to the village (min)	Average velocity based on MIKE 21 Results (m/s)	Average velocity based on simple Manning Eq. (m/s)
63.2	380	40.25	0.24	0.33
82.5	380	20.25	0.47	0.33

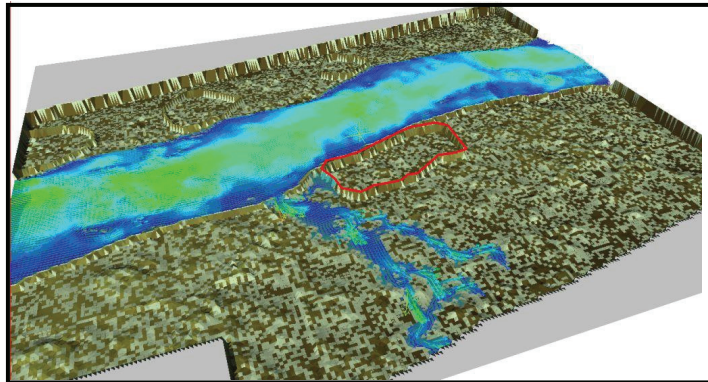

Fig. 19. Second dike-break scenario, 30 min after the break (Dashti shabankare ring dike in red, upstream is located on the right side)

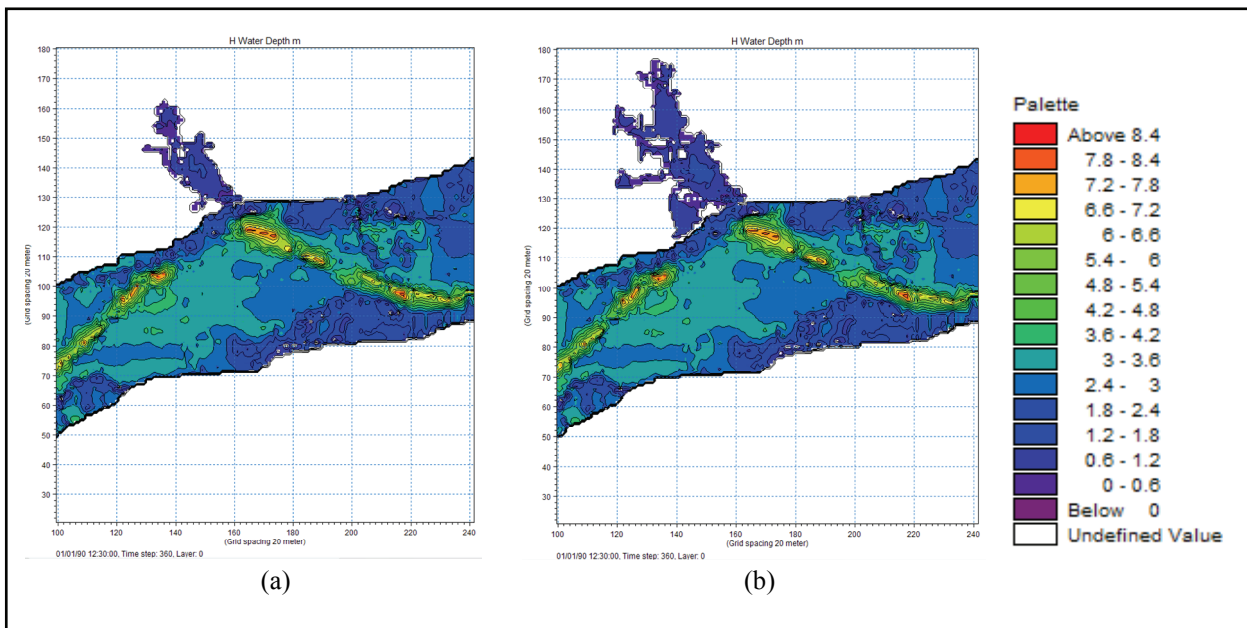

Fig. 20. Water depth contours, 30 min after the break in the second scenario (upstream is located on the right side), breach width: (a) 63.2 m (b) 82.5 m

It should be mentioned that MIKE21 is developed for simulation of flow in seas and coastal areas. Hence, simulation of flow in rivers and floodplains is accompanied by some limitations. Continuous wetting and drying -resulted from modeling flow on dry beds- is a major issue which leads to instabilities. Existence of sudden bumps and dips causes a model with instabilities; so, it's important to interpolate a smooth bathymetry and topography for the model.



Courant number equal to 5 was selected to satisfy the stability requirements. This limitation imposed a 5 second time step which severely increased the computational cost. For example, to rout a 380 *hr* hydrograph by HEC-RAS and MIKE21 models, a CPU time of 6 minutes was needed when HEC-RAS was used; whereas, almost 11 *hr* CPU time was needed when MIKE 21 was used (with a 2.6 GHz of CPU and 512Mb of RAM).

## 5. CONCLUSION

Different situations were considered in this study to evaluate the performance of MIKE21 in simulation of dam and dike-break compared with some of the available bench marks. Stoker analytical solution was set as a criterion for comparison of one-dimensional dam-break results. MIKE21 results were compared with two other numerical methods, namely MacCormack and Gubutti for two-dimensional dam-break. Results of two experimental studies, one specifically designed for dike-break, were also considered to evaluate the MIKE21 results. Generally, the model is capable of simulating dam and dike-breaks. The model results are sensitive to eddy viscosity and considerable care must be taken when modeling shock waves. In the regions of highly curved flow, three dimensional models might possibly give better results. Proper determination of eddy viscosity depends on numerical experiences and is generally complicated. As shock wave height depends on the difference between head water and tail water depths, shock waves generated by dam-break are much stronger than those caused by dike-break (due to the taller height of the dam compared to dike). Hence, modeling dike-break with MIKE21 is expected to end in more reliable results than dam-break. Finally, real cases of dike-break were investigated in the Helleh River in Iran. Results of this study indicated that in the case of dike breach, flood propagates in all directions. This phenomenon is due to very low flow gradient/ land relief of the flood plain. In such cases one-dimensional models are insufficient to represent the flow conditions, and utilization of two-dimensional models is highly recommended, although these models bring about higher computational costs. Wetting and drying in MIKE21 may be the cause of instabilities, which necessitate interpolation of smooth bathymetry and topography to avoid numerical instability. When the flow is restricted between levees the maximum flood stage is properly predicted by the one-dimensional model, however, time to peak is underestimated. By aid of two-dimensional simulation, the impact of fuse plug locations on the neighboring areas can be studied. This is an essential factor in design of fuse plug spillways for the dike system. Overall, the results showed that the model can reasonably simulate the flow propagation on topography and dry bed.

**Acknowledgement:** MIKE21 is used under the license of DHI in this study and the authors are thankful to DHI. Dr. Francesca Aureli and Professor Paolo Mignosa from Parma University, Italy, are acknowledged for their kind cooperation and providing experimental data. Also, the authors thank the anonymous reviewers of IJST for their cooperation in enhancing the paper quality.

## REFERENCES

1. Aureli, F., Marazoni, A., Mignosa, P. & Ziveri, Ch. (2008). Dam-break flows: acquisition of experimental data through an imaging technique and 2d numerical modeling. *Journal of Hydraulic Engineering*. Vol. 134, No. 8, pp. 1089-1101.
2. Ritter, A. (1892). Die fortpflanzung der wasserwellen. *Zeitschrift des Vereines Deutscher Ingenieure*. Vol. 36, No. 3, pp. 974-954.
3. Dressler, R. F. (1952). Hydraulic resistance effect upon dam-break function. *Journal of Research of the National Bureau of Standard*. Vol. 49, No. 3.
4. Stoker, J. J. (1957). *Water waves*. Interscience Publishers, Wiley, New York.

5. Hunt, B. (1983). Asymptotic solution for dam break on sloping channel. *Journal of Hydraulic Engineering*. Vol. 109, No. 12, pp. 1089-1101.
6. Wu, Ch. Huang, G. Zheng, Y. (1999). Theoretical solution of dam-break shock wave. *Journal of Hydraulic Engineering*. Vol. 125, No. 11, pp. 1210-1215.
7. Yost, S. A. & Rao, M. S. V. (1998). A non-oscillatory scheme for open channel flows. *Journal of Advances in Water Resource*. Vol. 22, No. 2, pp. 133-143.
8. Leal, B. et. al. (2006). Dam-break wave-front celerity. *Journal of Hydraulic Engineering*. Vol. 132, No. 1, pp. 69-76.
9. Zhao, D. H. et. al. (1996). Approximate Riemann solvers in F.V.M for 2D hydraulic shock wave modeling. *Journal of Hydraulic Engineering*. Vol. 122, No. 12, pp. 692-702.
10. Zoppou, C. & Roberts, S. (2000). Numerical solution of the two-dimensional unsteady dam break. *Journal of Applied Mathematical Modelling*. Vol. 24, pp. 457-475.
11. Aureli, F. and Mignosa, P. (2001). Comparison between experimental and numerical results of 2D flows due to levee-breaking. *Proceedings of XXIX IAHR Congress*. No.252, Beijing: China.
12. Gottardi, G. & Venutelli, M. (2004). Central scheme for two-dimensional dam-break flow simulation. *Journal of Advances in Water Resources*. Vol. 27, pp. 259-267.
13. McCown, A. D., Rasmussen, E. & Berg, P. (2001). Improving the performance of a two-dimensional hydraulic model for floodplain applications. *Proceedings of the Conference on Hydraulics in Civil Engineering, the Institution of Engineers*, Australia.
14. Abedini, M. J. & Hashemi, M. R. (2006). Effect of convective term suppression in numerical simulation of trans-critical open channel flow. *Iranian Journal of Science & Technology, Transaction B, Engineering*, Vol. 30, No. B1, pp. 85-96.
15. Zolghadr, M., Hashemi, M. R. & Zomorodian, M. A. (2009). Two dimensional simulation of flow around dike breaches. *Proceedings of the 8<sup>th</sup> International Congress on Civil Engineering*, Shiraz University, Shiraz, Iran.
16. Danish Hydraulic Institute (2000). MIKE21 flow model, hydrodynamic module, scientific documentation. *Denmark*.
17. Chaudhry, M. H. (1993). *Open channel flow*. New Jersey: Prentice-Hall Inc.
18. Liang, D. Falconer, R. A. & Binliang, L. (2006). Comparison between TVD-MacCormack and ADI-Type solvers of the shallow water equations. *Journal of Advances in Water Resources*. Vol. 29, pp. 1833-1845.
19. Liang, Q., Borthwick, A. G. L. & Stelling, G. (2004). Simulation of dam- and dyke-break hydrodynamics on dynamically adaptive quadtree grids. *International Journal for Numerical Methods in Fluids*. Vol. 46, pp. 127-162.
20. Fagherazzi, S., Rasetarinera, P., Yousuff Hussaini, M. & Furbish, D. J. (2004). Numerical solution of the dam-break problem with a discontinuous Galerkin method. *Journal of Hydraulic Engineering*. Vol. 130, No. 6, pp. 532-539.
21. Baghlani, A., Talebbeydokhti, N. & Abedini, M. J (2008). A shock-capturing model based on flux-vector splitting method in boundary-fitted curvilinear coordinates. *Journal of Applied Mathematical Modelling*. Vol. 32, pp. 249-266.
22. Vorogushyn, S., Apel, H., Lindenschmidt, K. E. & Merz, B. (2006). Coupling 1D hydrodynamic, dike breach and inundation models for large-scale flood risk assessment along the Elbe River. *Proceedings of the 7<sup>th</sup> International Conference on Hydroinformatics*, France.
23. Kamrath, P., Disse, M., Hammer, M. & Kongeter, J. (2006). Assessment of discharge through a dike breach and simulation of flood wave propagation. *Journal of Natural Hazards*, Vol. 38, pp. 63-78.
24. Toro, E. F. (2001). *Shock-capturing methods for free-surface shallow flows*. John Wiley and Sons, New York.